

**Reference: AVI97X3ZI**  
**3-compartments service wine cabinet**  
**Built-in range**

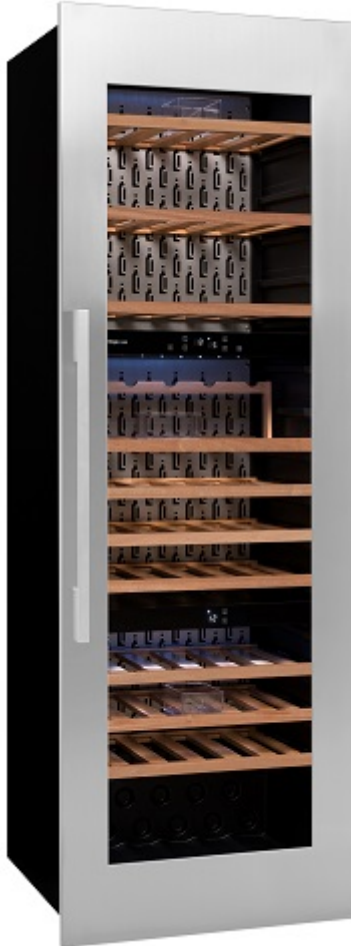

- + Capacity: 97 bottles\*
- + Built-in installation
- + Design: black body & stainless steel door frame
- + Cooling system: compressor (air moving system)
- + Adjustable temperature ranges of use: 5°-20°C/5°-10°C/10°-20°C
- + Electronic regulation
- + Thermometer with white electronic display
- + White LED lights with switch button
- + Humidity control: water tray
- + 1 reversible glass door, anti-UV treated, 2-layers tempered glass (brown colored)

*Big format **3-compartments built-in** wine cellar: 174,5cm (built-in height).*

*A **presentation shelf** allows you to present up to 5 bottles.*

*\*Capacity given as an indication without presentation shelf. Adding shelves reduces considerably the total capacity.*



## Eco-responsibility

Our products are manufactured in compliance with European environmental rules. Especially, refrigerant fluid (R600a) doesn't reject neither CFC nor HFC and respect environment.

Energy consumption is calculated based on the result obtained for 24h in standard test conditions. The actual energy consumption depends on the conditions of use and location of the device.

This equipment is designed to be used in an ambient temperature between 0-32°C.

This appliance is intended to be used exclusively for the storage of wine.

Alcohol abuse is dangerous for health, please consume in moderation.

\*Capacity given as an indication with 75cl Bordeaux traditional type bottles and measured with 10 shelves. Adding shelves reduce considerably the total capacity.



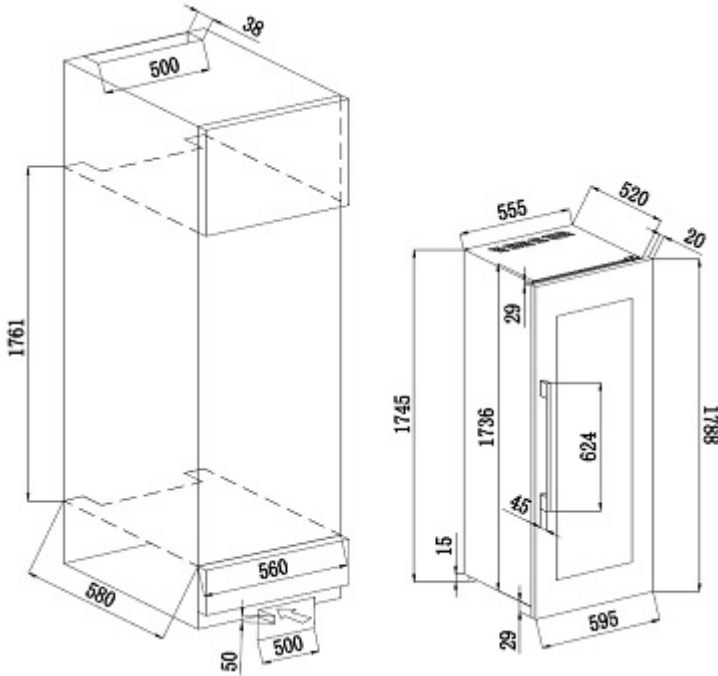

#### > EQUIPMENTS INCLUDED

- 9 sliding wooden shelves (beech), wooden front
- 1 sliding wooden presentation shelf (beech), wooden front
- 4 adjustable feet (height 3 cm)
- Anti-vibration system

#### > TECHNICAL CHARACTERISTICS

- Energy class: B
- Annual electrical consumption: 216 kWh
- Climatic class: N (0-32°C)
- Noise level: 45 dB
- Voltage: 220-240 V
- Power input: 165 W
- Category: 2 - Wine cellar
- Type of gas : R600a

#### > SAFETY

- **Winter system:** maintains the required temperature of your cellar in case of any ambient temperature drop, ideal during winter

#### > LOGISTIC DATAS

Gross dimensions (WxDxH cm)	: 65,5 x 66 x 186,5
Net dimensions (WxDxH cm)	: 59,5 x 54 x 178,8
Gross weight (kg)	: 116.00
Net weight (kg)	: 106.00
Full truck (pcs)	: 60
Container (pcs)	20' : 24
	40' : 54
	40' HC : 54

Gencod 3595320104516

#### > COMPATIBLE ACCESSORIES

Only available in spare parts