

avintage

Built-under range

Single-compartment service wine cabinet

50 bottles*

AVU52SX

- *Free standing and built-under counter installation*
- *Cooling system: compressor (air moving system)*
- *Adjustable temperature range of use: 5°-20°C*
- *Black metal external body*
- *Black PVC inner liner*
- *1 reversible glass door, anti-UV treated, 3-layers tempered glass (brown colored), stainless steel frame*
- *Electronic regulation*
- *3 semi-sliding wooden shelves*
1 semi-sliding wooden half shelf

*New elegant design and optimization of energy consumption: **A class.***



avintage

Reference: **AVU52SX**

- **Ambient temperature range of use:**
16°-32°C
- **Equipments included:**
4 adjustable feet (height 6.5 cm)
Plumbing passage
White LED lights with ON/OFF switch button
Anti-vibration system
Removable aeration system
Water tray to maintain proper hygrometry
Thermometer with white electronic display
- **Technical characteristics:**
Voltage: 220-240 V
Power input: 100.0 W
Annual electrical consumption: 145.0 kWh
Energy class: A
Climatic class: N
Noise level: 44.0 dB
- **Logistic datas:**

Dimension UVC (W x D x H cm):

Packed: 65.5 x 66.5 x 87
Unpacked: 59.5 x 57.1 x 82

Weight UVC (Kg):

Gross: 48,00
Net: 44,00

Pallet dimensions (cm): 0

Full truck (UVC): 120

Container (UVC):

20': 48
40': 108
40' HC: 162

Gencod UVC: 3595320104745

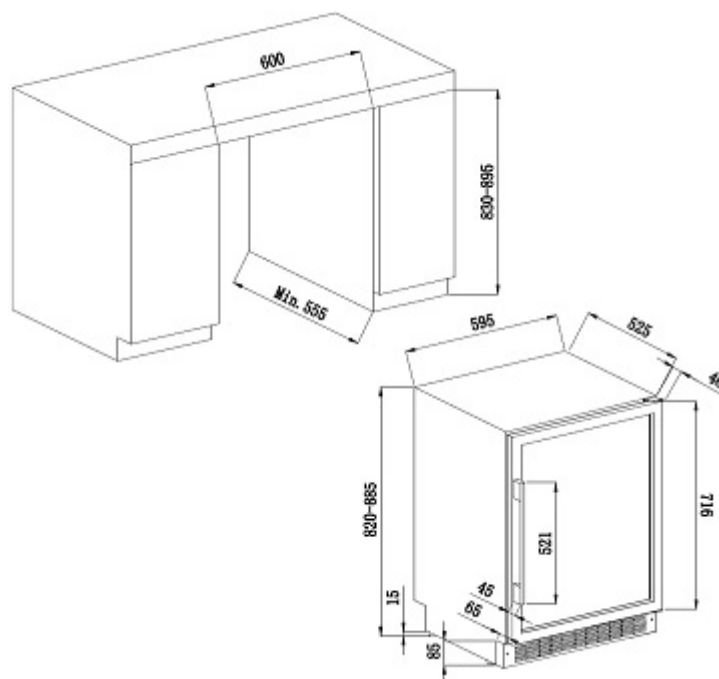

Non-contractual pictures

* Capacity given with 75cl Bordeaux traditional type bottles.
Adding shelves reduce considerably the total capacity.