

avintage

Built-under range

2-compartments service wine cabinet

50 bottles*

AVU53CDZA

- *Free standing and built-under counter installation*
- *Cooling system: compressor (air moving system)*
- *Adjustable temperature ranges of use:
5°-10°C/10°-20°C*
- *Black metal external body*
- *Black PVC inner liner*
- *1 reversible glass door, anti-UV treated, 2-layers
tempered glass (brown colored), black frame*
- *Electronic regulation*
- *4 semi-sliding wooden shelves
1 semi-sliding wooden half shelf*

*New elegant design and optimization of energy
consumption: **A class.***



avintage

Reference: **AVU53CDZA**

- **Ambient temperature range of use:**
0°-32°C
- **Equipments included:**
4 adjustable feet (height 6.5 cm)
Plumbing passage
White LED lights with ON/OFF switch button
Anti-vibration system
Removable aeration system
Winter system
Water tray to maintain proper hygrometry
Thermometer with white electronic display
- **Technical characteristics:**
Voltage: 220-240 V
Power input: 100.0 W
Annual electrical consumption: 145.0 kWh
Energy class: A
Climatic class: N
Noise level: 45.0 dB

- **Logistic datas:**

Dimension UVC (W x D x H cm):

Packed: 65.5 x 66.5 x 87
Unpacked: 59.5 x 57.1 x 82

Weight UVC (Kg):

Gross: 54,00
Net: 50,00

Pallet dimensions (cm): 0

Full truck (UVC): 120

Container (UVC):

20': 48
40': 108
40' HC: 162

Gencod UVC: 3595320105094

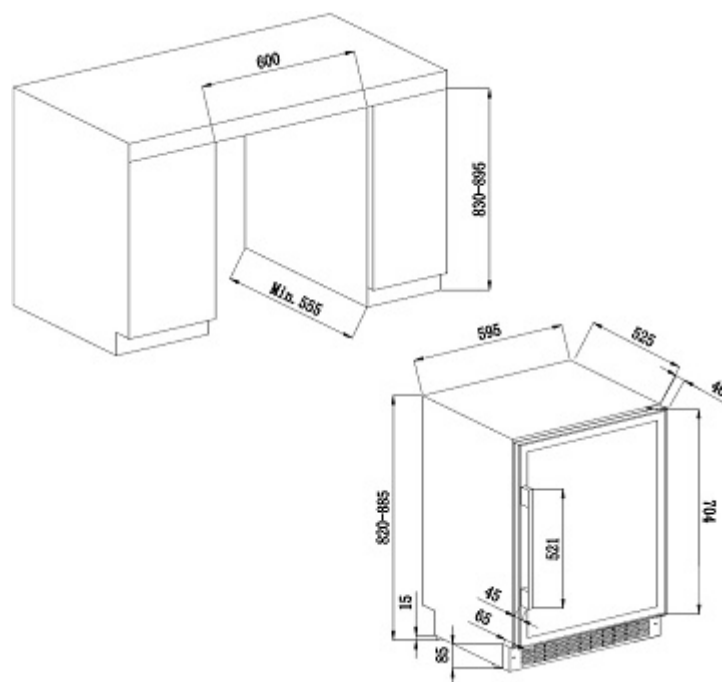

Non-contractual pictures

* Capacity given with 75cl Bordeaux traditional type bottles on 3 shelves. Adding shelves reduce considerably the total capacity.