

avintage

Built-in range

2-compartment service wine cabinet

52 bottles*

AVI47XDZ

- Built-in column
- Cooling system: compressor (air moving system)
- Adjustable temperature ranges of use:
5°-18°C/5°-18°C
- Black metal external body
- Black PVC inner liner
- 1 reversible glass door, anti-UV treated, 3-layers tempered glass (grey-colored), stainless steel frame
- Electronic regulation
- 4 semi-sliding wooden shelves
1 fixed de présentation en bois shelf

Opt for the **elegant design** of this cabinet which will fit perfectly into your kitchen and will keep your wines at a constant temperature.

Thanks to its both temperature zones, you could bring **simultaneously** your bottles at **room temperature** or bring them to **service temperature**.

*Capacity given as an indication without presentation shelf. Adding shelves reduces considerably the total capacity.



avintage

Reference: AVI47XDZ

- **Ambient temperature range of use:**
10°-32°C
- **Equipments included:**
2 adjustable feet (height 1 cm)
White LED lights with ON/OFF switch button
Anti-vibration system
Thermometer with white electronic display
- **Technical characteristics:**
Voltage: 220-240 V
Power input: 85.0 W
Annual electrical consumption: 190.0 kWh
Energy class: B
Climatic class: N-SN
Noise level: 41.0 dB

- **Logistic datas:**

Dimension UVC (W x D x H cm):

Packed: 65 x 65 x 94
Unpacked: 59.5 x 55.6 x 88.7

Weight UVC (Kg):

Gross: 49,00
Net: 45,00

Pallet dimensions (cm): /

Full truck (UVC): 120

Container (UVC):

20': 54
40': 108
40' HC: 148

Gencod UVC: 3595320104677

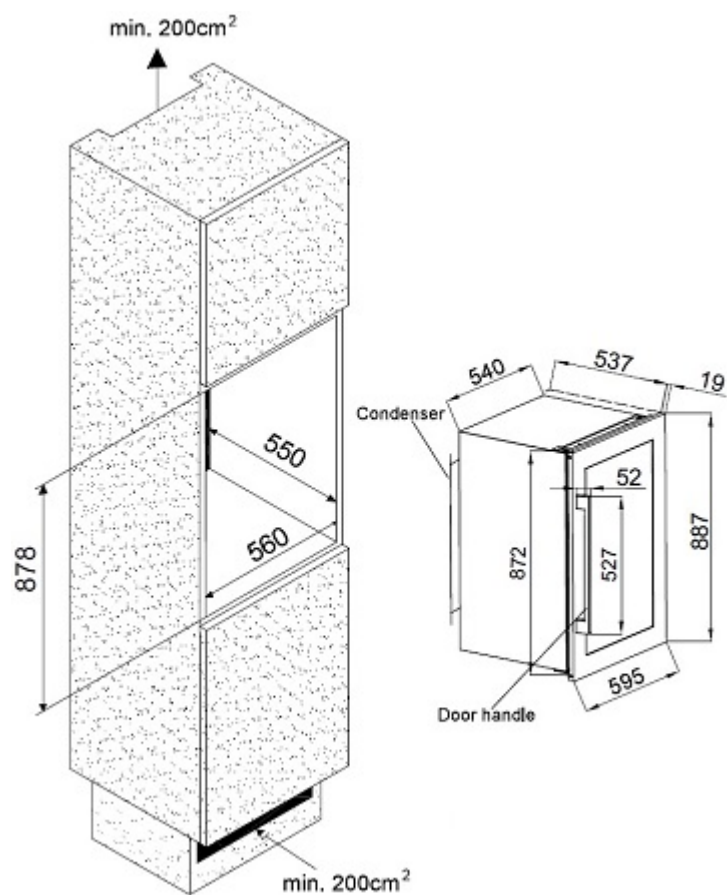

Non-contractual pictures

* Capacity given with 75cl Bordeaux traditional type bottles on 4 shelves. Adding shelves reduce considerably the total capacity.